



UMR-A-10000 SERIES

0 to 10kV, 4 to 30W
Standard DC/DC Modules



Features

- Biasing High Voltage Power Supplies
- Regulated Output Voltage from V_{OUT} Max to True 0
- Low Ripple
- Output Short Circuit Protection
- Output Current and Voltage Monitors
- Fixed-Frequency, Low-Stored-Energy Design
- UL/cUL Pending Components; CE Mark (LVD and RoHS)

Specifications

		Conditions			Units
		4W	15W	30W	
Input					
Voltage	Nominal	+12	+24	+24	VDC
Voltage Range	Full Power	+11 to 16	+23 to 30	+23 to 30	VDC
Voltage Range	Derated Power Range	+10 to 32	+10 to 32	+10 to 32	VDC
Current	Standby/Disable	<80	<80	<80	mA
Current	No Load, Max V_{OUT}	<150	<150	<150	mA
Current	Max Load, Max V_{OUT}	<500	<1000	<1500	mA
AC Ripple Current	Nominal Input, Full Load	<100	<100	<100	mAp-p
Output					
Static Load Regulation	No Load to Full Load, Max V_{OUT}	<0.01	<0.01	<0.01	%VDC
Line Regulation	Nominal Input, Max V_{OUT} , Full Power	<0.08	<0.08	<0.08	%VDC
Stability	30-minute warmup, per 8h/per day	<0.01 / <0.02	<0.01 / <0.02	<0.01 / <0.02	%VDC
Programming & Controls					
Input Impedance	Nominal Input, Positive Models	1.0 to Signal Ground			M Ω
	Nominal Input, Negative Models	0.01 to V_{REF}			
Adjust Reference	Typical Potentiometer Values	10K to 100K (Pot Across V_{REF} and Signal Ground, Wiper to Adjust)			Ω
Adjust Logic	Positive Models	0 to +4.64 = 0 to 100% Rated Output			VDC
	Negative Models	+5 to +0.36 = 0 to 100% Rated Output			
Reference Logic	Temperature +25°C	+5 \pm 0.5%			VDC
Enable/Disable HV_{OUT}	-	Unconnected = Enabled Ground to +0.5 = Disabled, +2.4 to 32 Enabled			VDC
Environmental					
Operating	Full Load, Max E_{OUT} , Case Temperature	-40 to +65			°C
Coefficient	Over the Specified Temperature	\pm 50			PPM/°C
Thermal Shock	Mil-Std-810, Method 503-4, Proc. II	-40 to +65			°C
Storage	Non-Operating, Case Temperature	-55 to +105			°C
Humidity	All Conditions, Standard Package	0 to 95% Non-Condensing			-
Altitude	All Conditions, Standard Package	Sea Level through Vacuum			-
Shock	Mil-Std-810, Method 516.5, Proc IV	20			G
Vibration	Mil-Std-810, Method 514.5, Fig 514.5C-3	10			G

Part Number ¹	Output Voltage VDC	Output Power W	Output Current mA	High Freq. Ripple ² %Vp-p	Output Capacitance μ F	I _{MON} Scaling ³ mA/V	V _{MON} Scaling ⁴ V
All Models							
UMR-A-10000•-4	0 to 10000	4	0.4	<0.020	2	0.167	1000:1 \pm 2%
UMR-A-10000•-15	0 to 10000	15	1.5	<0.040	2	0.184	1000:1 \pm 2%
UMR-A-10000•-30	0 to 10000	30	3.0	<0.076	2	0.381	1000:1 \pm 2%

¹For “•”, substitute “P” for positive output or “N” for negative output

²1Hz to 1MHz, Full Load

³Full Scale Signal

⁴Into 10M Ω Meter

Drawings, Mechanical and Pin Definitions

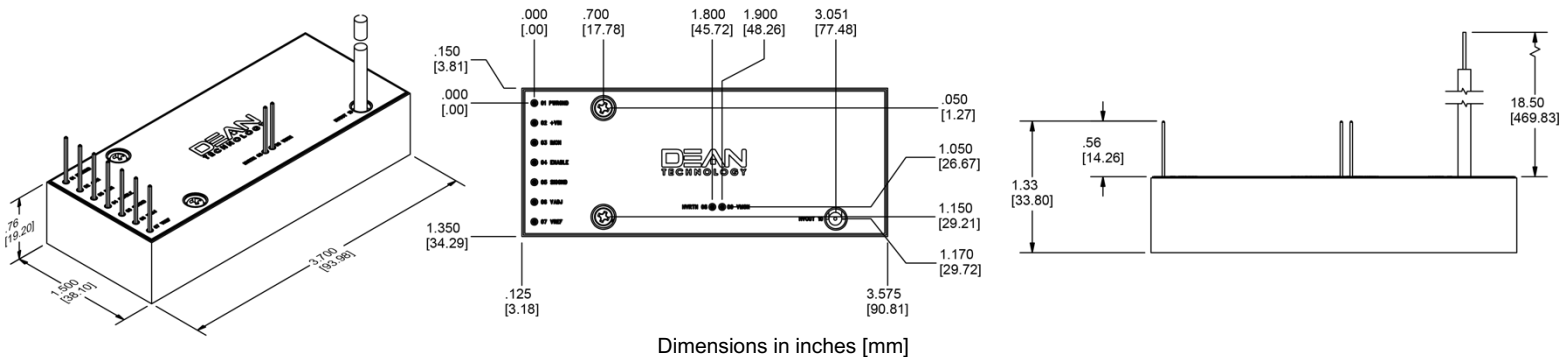

Mechanical Specifications	
Volume	4.3in ³ [70.5cm ³]
Weight	5.0oz [142g]
Case	DAP case certified to ASTM-D-5948
Pins	Pins 1-7 0.200in Spacing Pins 8-9 0.100in Spacing

Tolerances	
Overall	0.050in [\pm 1.27mm]
Pin to Pin	0.015in [\pm 0.38mm]
Mounting	0.025in [\pm 0.64mm]

Pin Assignments & Connections		
Pin 1	-VIN	Input Power Ground Return
Pin 2	+VIN	Positive Power Input
Pin 3	IMON	Output Current Monitor
Pin 4	ENABLE	Enable/Disable
Pin 5	SIGGND	Signal Ground Return
Pin 6	VADJ	Voltage Adjust
Pin 7	VREF	Voltage Reference
Pin 8	HVRTN	High Voltage Ground Return
Pin 9	VMON	Output Voltage Monitor
Flying Lead	HVOUT	High Voltage Output

Options

Append to Part #	Option Description	Not Compatible With
-V05	Enhanced Controls and Monitors, 0 to +5VDC	-
-V10	Enhanced Controls and Monitors, 0 to +10VDC	4W models

V05 and V10 Options

Conditions		Value	Units
Output			
Current Scaling (I_{MON})	V05 Option, Buffered Signal	0 to +5 = 0 to 100% Rated Output	VDC
	V10 Option, Buffered Signal	0 to +10 = 0 to 100% Rated Output	
Voltage Scaling (V_{MON})	V05 Option, Buffered Signal	0 to +5 = 0 to 100% Rated Output	VDC
	V10 Option, Buffered Signal	0 to +10 = 0 to 100% Rated Output	
Programming & Controls			
Adjust Logic (I_{ADJ} & V_{ADJ})	V05 Option	0 to +5 = 0 to 100% Rated Output	VDC
	V10 Option	0 to +10 = 0 to 100% Rated Output	
Reference Voltage (V_{REF})	V05 Option	+5 \pm 0.5%, 10mA Source	VDC
	V10 Option	+10 \pm 0.5%, 30mA Source	
Enable/Disable HV_{OUT}	-	Unconnected = Disabled; Ground to +0.5 = Disabled; +2.4 to 32 = Enabled	VDC
Mode Indicator	IMODE	Open Drain, Pulled Low When Active, 0 to 60V and 100mA Max	-
	VMODE	Open Drain, Pulled Low When Active, 0 to 60V and 100mA Max	

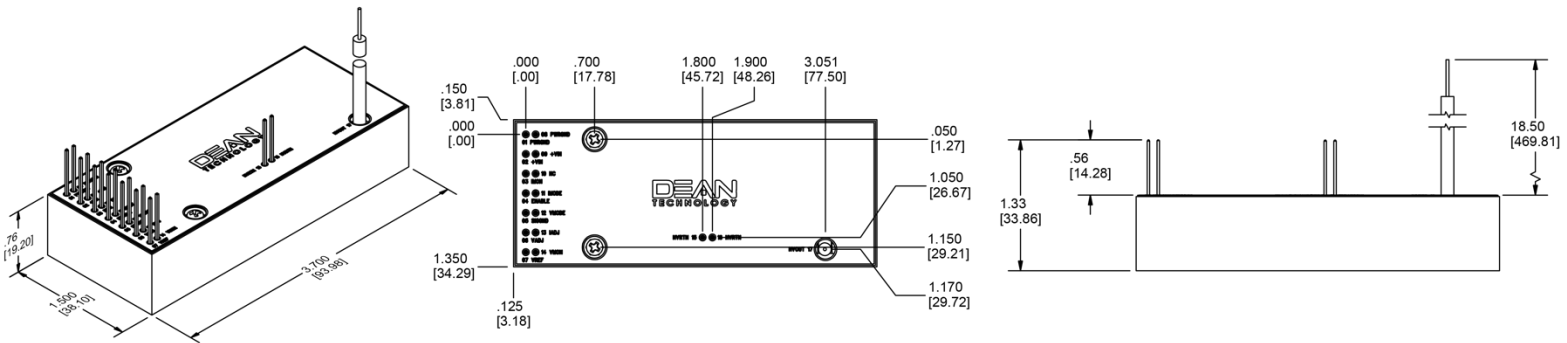

Dimensions in inches [mm]

Mechanical Specifications	
Volume	4.3in ³ [70.5cm ³]
Weight	5.0oz [142g]
Case	DAP case certified to ASTM-D-5948
Pins	Pins 1-7, 8-14 0.200in Spacing
	Pins 15-16, 17-18 0.100in Spacing

Tolerances	
Overall	0.050in [\pm 1.27mm]
Pin to Pin	0.015in [\pm 0.38mm]
Mounting	0.025in [\pm 0.64mm]

Pin Assignments & Connections		
Pin 1, 8	PWRGND	Input Power Ground Return
Pin 2, 9	+VIN	Positive Power Input
Pin 3	IMON	Output Current Monitor
Pin 4	ENABLE	Enable/Disable
Pin 5	SIGGND	Signal Ground Return
Pin 6	VADJ	Voltage Adjust
Pin 7	VREF	Voltage Reference
Pin 10	N/C	N/C
Pin 11	IMODE	Current Mode Indicator
Pin 12	VMODE	Voltage Mode Indicator
Pin 13	IADJ	Current Adjust
Pin 14	VMON	Output Voltage Monitor
Pin 15, 16	HVRTN	High Voltage Ground Return
Flying Lead	HVOUT	High Voltage Output



UMR-A-10000 SERIES

Certifications and Compliances

