

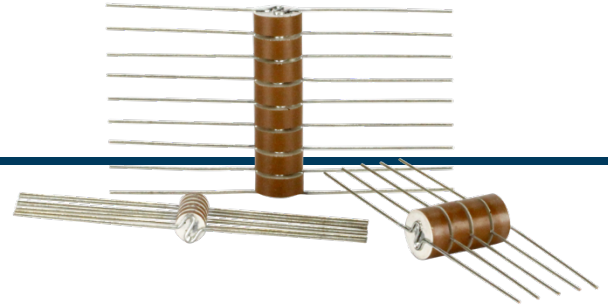

ST1 SERIES

6 to 12kV, 250 to 1000pF
Capacitor Stacks



Features

- Capacitor Stacks with Leads, Class II
- Silver Plated Electrodes
- Use in Oil or Encapsulated
- Multiple Configurations Standard; Custom Versions Available

Specifications

Part Number ¹	C ² pF	Tolerance ±%	V _{RATE} ³ kVDC	V _{WITHSTAND} kVDC	# of Discs	L ⁴ in [mm]	D ⁴ in [mm]	T ⁵ in [mm]	A ⁶ in [mm]
Y5P Dielectric Subseries									
ST1Y5P251•10KV04	250	K,M,Z	10.0	15.0	4	0.78 [19.9]	0.25 [6.5]	0.17 [4.4]	2.75 [70.0]
ST1Y5P251•10KV05	250	K,M,Z	10.0	15.0	5	0.97 [24.7]	0.25 [6.5]	0.17 [4.4]	2.75 [70.0]
ST1Y5P251•10KV06	250	K,M,Z	10.0	15.0	6	1.16 [29.5]	0.25 [6.5]	0.17 [4.4]	2.75 [70.0]
ST1Y5P251•10KV07	250	K,M,Z	10.0	15.0	7	1.35 [34.3]	0.25 [6.5]	0.17 [4.4]	2.75 [70.0]
ST1Y5P251•10KV08	250	K,M,Z	10.0	15.0	8	1.54 [39.1]	0.25 [6.5]	0.17 [4.4]	2.75 [70.0]
ST1Y5P251•10KV09	250	K,M,Z	10.0	15.0	9	1.73 [43.9]	0.25 [6.5]	0.17 [4.4]	2.75 [70.0]
ST1Y5P251•10KV10	250	K,M,Z	10.0	15.0	10	1.92 [48.7]	0.25 [6.5]	0.17 [4.4]	2.75 [70.0]
ST1Y5P251•10KV11	250	K,M,Z	10.0	15.0	11	2.10 [53.4]	0.25 [6.5]	0.17 [4.4]	2.75 [70.0]
ST1Y5P251•10KV12	250	K,M,Z	10.0	15.0	12	2.29 [58.2]	0.25 [6.5]	0.17 [4.4]	2.75 [70.0]
ST1Y5P251•12KV04	250	K,M,Z	12.0	18.0	4	0.87 [22.0]	0.27 [6.9]	0.19 [4.9]	2.75 [70.0]
ST1Y5P251•12KV05	250	K,M,Z	12.0	18.0	5	1.08 [27.4]	0.27 [6.9]	0.19 [4.9]	2.75 [70.0]
ST1Y5P251•12KV06	250	K,M,Z	12.0	18.0	6	1.29 [32.7]	0.27 [6.9]	0.19 [4.9]	2.75 [70.0]
ST1Y5P251•12KV07	250	K,M,Z	12.0	18.0	7	1.50 [38.0]	0.27 [6.9]	0.19 [4.9]	2.75 [70.0]
ST1Y5P251•12KV08	250	K,M,Z	12.0	18.0	8	1.71 [43.4]	0.27 [6.9]	0.19 [4.9]	2.75 [70.0]
ST1Y5P251•12KV09	250	K,M,Z	12.0	18.0	9	1.92 [48.7]	0.27 [6.9]	0.19 [4.9]	2.75 [70.0]
ST1Y5P251•12KV10	250	K,M,Z	12.0	18.0	10	2.13 [54.0]	0.27 [6.9]	0.19 [4.9]	2.75 [70.0]
ST1Y5P251•12KV11	250	K,M,Z	12.0	18.0	11	2.34 [59.4]	0.27 [6.9]	0.19 [4.9]	2.75 [70.0]
ST1Y5P251•12KV12	250	K,M,Z	12.0	18.0	12	2.55 [64.7]	0.27 [6.9]	0.19 [4.9]	2.75 [70.0]
ST1Y5P501•6KV04	500	K,M,Z	6.0	9.0	4	0.41 [10.5]	0.24 [6.2]	0.09 [2.3]	2.75 [70.0]
ST1Y5P501•6KV05	500	K,M,Z	6.0	9.0	5	0.51 [12.9]	0.24 [6.2]	0.09 [2.3]	2.75 [70.0]
ST1Y5P501•6KV06	500	K,M,Z	6.0	9.0	6	0.61 [15.4]	0.24 [6.2]	0.09 [2.3]	2.75 [70.0]
ST1Y5P501•6KV07	500	K,M,Z	6.0	9.0	7	0.70 [17.8]	0.24 [6.2]	0.09 [2.3]	2.75 [70.0]
ST1Y5P501•6KV08	500	K,M,Z	6.0	9.0	8	0.80 [20.3]	0.24 [6.2]	0.09 [2.3]	2.75 [70.0]
ST1Y5P501•6KV09	500	K,M,Z	6.0	9.0	9	0.89 [22.7]	0.24 [6.2]	0.09 [2.3]	2.75 [70.0]
ST1Y5P501•6KV10	500	K,M,Z	6.0	9.0	10	0.99 [25.2]	0.24 [6.2]	0.09 [2.3]	2.75 [70.0]
ST1Y5P501•6KV11	500	K,M,Z	6.0	9.0	11	1.09 [27.6]	0.24 [6.2]	0.09 [2.3]	2.75 [70.0]
ST1Y5P501•6KV12	500	K,M,Z	6.0	9.0	12	1.18 [30.0]	0.24 [6.2]	0.09 [2.3]	2.75 [70.0]
ST1Y5P501•8KV04	500	K,M,Z	8.0	12.0	4	0.51 [13.0]	0.28 [7.1]	0.11 [2.9]	2.75 [70.0]
ST1Y5P501•8KV05	500	K,M,Z	8.0	12.0	5	0.63 [16.1]	0.28 [7.1]	0.11 [2.9]	2.75 [70.0]
ST1Y5P501•8KV06	500	K,M,Z	8.0	12.0	6	0.75 [19.1]	0.28 [7.1]	0.11 [2.9]	2.75 [70.0]
ST1Y5P501•8KV07	500	K,M,Z	8.0	12.0	7	0.87 [22.2]	0.28 [7.1]	0.11 [2.9]	2.75 [70.0]
ST1Y5P501•8KV08	500	K,M,Z	8.0	12.0	8	0.99 [25.3]	0.28 [7.1]	0.11 [2.9]	2.75 [70.0]
ST1Y5P501•8KV09	500	K,M,Z	8.0	12.0	9	1.12 [28.3]	0.28 [7.1]	0.11 [2.9]	2.75 [70.0]
ST1Y5P501•8KV10	500	K,M,Z	8.0	12.0	10	1.24 [31.4]	0.28 [7.1]	0.11 [2.9]	2.75 [70.0]
ST1Y5P501•8KV11	500	K,M,Z	8.0	12.0	11	1.36 [34.5]	0.28 [7.1]	0.11 [2.9]	2.75 [70.0]
ST1Y5P501•8KV12	500	K,M,Z	8.0	12.0	12	1.48 [37.6]	0.28 [7.1]	0.11 [2.9]	2.75 [70.0]



ST1 SERIES

Part Number ¹	C ² pF	Tolerance ±%	V _{RATE} ³ kVDC	V _{WITHSTAND} kVDC	# of Discs	L ⁴ in [mm]	D ⁴ in [mm]	T ⁵ in [mm]	A ⁶ in [mm]
ST1Y5P501•10KV04	500	K,M,Z	10.0	15.0	4	0.74 [18.9]	0.35 [8.9]	0.17 [4.2]	2.75 [70.0]
ST1Y5P501•10KV05	500	K,M,Z	10.0	15.0	5	0.92 [23.4]	0.35 [8.9]	0.17 [4.2]	2.75 [70.0]
ST1Y5P501•10KV06	500	K,M,Z	10.0	15.0	6	1.10 [28.0]	0.35 [8.9]	0.17 [4.2]	2.75 [70.0]
ST1Y5P501•10KV07	500	K,M,Z	10.0	15.0	7	1.28 [32.5]	0.35 [8.9]	0.17 [4.2]	2.75 [70.0]
ST1Y5P501•10KV08	500	K,M,Z	10.0	15.0	8	1.46 [37.0]	0.35 [8.9]	0.17 [4.2]	2.75 [70.0]
ST1Y5P501•10KV09	500	K,M,Z	10.0	15.0	9	1.64 [41.6]	0.35 [8.9]	0.17 [4.2]	2.75 [70.0]
ST1Y5P501•10KV10	500	K,M,Z	10.0	15.0	10	1.82 [46.1]	0.35 [8.9]	0.17 [4.2]	2.75 [70.0]
ST1Y5P501•10KV11	500	K,M,Z	10.0	15.0	11	1.99 [50.7]	0.35 [8.9]	0.17 [4.2]	2.75 [70.0]
ST1Y5P501•10KV12	500	K,M,Z	10.0	15.0	12	2.17 [55.2]	0.35 [8.9]	0.17 [4.2]	2.75 [70.0]
ST1Y5P501•12KV04	500	K,M,Z	12.0	18.0	4	0.86 [21.9]	0.39 [10.0]	0.19 [4.9]	2.75 [70.0]
ST1Y5P501•12KV05	500	K,M,Z	12.0	18.0	5	1.07 [27.2]	0.39 [10.0]	0.19 [4.9]	2.75 [70.0]
ST1Y5P501•12KV06	500	K,M,Z	12.0	18.0	6	1.28 [32.5]	0.39 [10.0]	0.19 [4.9]	2.75 [70.0]
ST1Y5P501•12KV07	500	K,M,Z	12.0	18.0	7	1.49 [37.8]	0.39 [10.0]	0.19 [4.9]	2.75 [70.0]
ST1Y5P501•12KV08	500	K,M,Z	12.0	18.0	8	1.70 [43.1]	0.39 [10.0]	0.19 [4.9]	2.75 [70.0]
ST1Y5P501•12KV09	500	K,M,Z	12.0	18.0	9	1.91 [48.4]	0.39 [10.0]	0.19 [4.9]	2.75 [70.0]
ST1Y5P501•12KV10	500	K,M,Z	12.0	18.0	10	2.11 [53.7]	0.39 [10.0]	0.19 [4.9]	2.75 [70.0]
ST1Y5P501•12KV11	500	K,M,Z	12.0	18.0	11	2.32 [59.0]	0.39 [10.0]	0.19 [4.9]	2.75 [70.0]
ST1Y5P501•12KV12	500	K,M,Z	12.0	18.0	12	2.53 [64.3]	0.39 [10.0]	0.19 [4.9]	2.75 [70.0]
ST1Y5P102•6KV04	1000	K,M,Z	6.0	9.0	4	0.42 [10.7]	0.34 [8.7]	0.09 [2.3]	2.75 [70.0]
ST1Y5P102•6KV05	1000	K,M,Z	6.0	9.0	5	0.52 [13.1]	0.34 [8.7]	0.09 [2.3]	2.75 [70.0]
ST1Y5P102•6KV06	1000	K,M,Z	6.0	9.0	6	0.62 [15.6]	0.34 [8.7]	0.09 [2.3]	2.75 [70.0]
ST1Y5P102•6KV07	1000	K,M,Z	6.0	9.0	7	0.71 [18.1]	0.34 [8.7]	0.09 [2.3]	2.75 [70.0]
ST1Y5P102•6KV08	1000	K,M,Z	6.0	9.0	8	0.81 [20.6]	0.34 [8.7]	0.09 [2.3]	2.75 [70.0]
ST1Y5P102•6KV09	1000	K,M,Z	6.0	9.0	9	0.91 [23.1]	0.34 [8.7]	0.09 [2.3]	2.75 [70.0]
ST1Y5P102•6KV10	1000	K,M,Z	6.0	9.0	10	1.01 [25.6]	0.34 [8.7]	0.09 [2.3]	2.75 [70.0]
ST1Y5P102•6KV11	1000	K,M,Z	6.0	9.0	11	1.11 [28.1]	0.34 [8.7]	0.09 [2.3]	2.75 [70.0]
ST1Y5P102•6KV12	1000	K,M,Z	6.0	9.0	12	1.20 [30.6]	0.34 [8.7]	0.09 [2.3]	2.75 [70.0]
ST1Y5P102•8KV04	1000	K,M,Z	8.0	12.0	4	0.50 [12.7]	0.39 [9.9]	0.11 [2.8]	2.75 [70.0]
ST1Y5P102•8KV05	1000	K,M,Z	8.0	12.0	5	0.62 [15.7]	0.39 [9.9]	0.11 [2.8]	2.75 [70.0]
ST1Y5P102•8KV06	1000	K,M,Z	8.0	12.0	6	0.73 [18.7]	0.39 [9.9]	0.11 [2.8]	2.75 [70.0]
ST1Y5P102•8KV07	1000	K,M,Z	8.0	12.0	7	0.85 [21.7]	0.39 [9.9]	0.11 [2.8]	2.75 [70.0]
ST1Y5P102•8KV08	1000	K,M,Z	8.0	12.0	8	0.97 [24.7]	0.39 [9.9]	0.11 [2.8]	2.75 [70.0]
ST1Y5P102•8KV09	1000	K,M,Z	8.0	12.0	9	1.09 [27.6]	0.39 [9.9]	0.11 [2.8]	2.75 [70.0]
ST1Y5P102•8KV10	1000	K,M,Z	8.0	12.0	10	1.21 [30.6]	0.39 [9.9]	0.11 [2.8]	2.75 [70.0]
ST1Y5P102•8KV11	1000	K,M,Z	8.0	12.0	11	1.32 [33.6]	0.39 [9.9]	0.11 [2.8]	2.75 [70.0]
ST1Y5P102•8KV12	1000	K,M,Z	8.0	12.0	12	1.44 [36.6]	0.39 [9.9]	0.11 [2.8]	2.75 [70.0]
Z5U Dielectric Subseries									
ST1Z5U251•10KV04	250	K,M,Z	10.0	15.0	4	0.76 [19.3]	0.26 [6.5]	0.17 [4.2]	2.75 [70.0]
ST1Z5U251•10KV05	250	K,M,Z	10.0	15.0	5	0.94 [23.9]	0.26 [6.5]	0.17 [4.2]	2.75 [70.0]
ST1Z5U251•10KV06	250	K,M,Z	10.0	15.0	6	1.12 [28.5]	0.26 [6.5]	0.17 [4.2]	2.75 [70.0]
ST1Z5U251•10KV07	250	K,M,Z	10.0	15.0	7	1.31 [33.2]	0.26 [6.5]	0.17 [4.2]	2.75 [70.0]
ST1Z5U251•10KV08	250	K,M,Z	10.0	15.0	8	1.49 [37.8]	0.26 [6.5]	0.17 [4.2]	2.75 [70.0]
ST1Z5U251•10KV09	250	K,M,Z	10.0	15.0	9	1.67 [42.5]	0.26 [6.5]	0.17 [4.2]	2.75 [70.0]
ST1Z5U251•10KV10	250	K,M,Z	10.0	15.0	10	1.85 [47.1]	0.26 [6.5]	0.17 [4.2]	2.75 [70.0]
ST1Z5U251•10KV11	250	K,M,Z	10.0	15.0	11	2.04 [51.8]	0.26 [6.5]	0.17 [4.2]	2.75 [70.0]
ST1Z5U251•10KV12	250	K,M,Z	10.0	15.0	12	2.22 [56.4]	0.26 [6.5]	0.17 [4.2]	2.75 [70.0]



ST1 SERIES

Part Number ¹	C ² pF	Tolerance ±%	V _{RATE} ³ kVDC	V _{WITHSTAND} kVDC	# of Discs	L ⁴ in [mm]	D ⁴ in [mm]	T ⁵ in [mm]	A ⁶ in [mm]
ST1Z5U251•12KV04	250	K,M,Z	12.0	18.0	4	0.86 [21.7]	0.28 [7.0]	0.19 [4.8]	2.75 [70.0]
ST1Z5U251•12KV05	250	K,M,Z	12.0	18.0	5	1.06 [27.0]	0.28 [7.0]	0.19 [4.8]	2.75 [70.0]
ST1Z5U251•12KV06	250	K,M,Z	12.0	18.0	6	1.27 [32.2]	0.28 [7.0]	0.19 [4.8]	2.75 [70.0]
ST1Z5U251•12KV07	250	K,M,Z	12.0	18.0	7	1.48 [37.5]	0.28 [7.0]	0.19 [4.8]	2.75 [70.0]
ST1Z5U251•12KV08	250	K,M,Z	12.0	18.0	8	1.68 [42.7]	0.28 [7.0]	0.19 [4.8]	2.75 [70.0]
ST1Z5U251•12KV09	250	K,M,Z	12.0	18.0	9	1.89 [48.0]	0.28 [7.0]	0.19 [4.8]	2.75 [70.0]
ST1Z5U251•12KV10	250	K,M,Z	12.0	18.0	10	2.10 [53.3]	0.28 [7.0]	0.19 [4.8]	2.75 [70.0]
ST1Z5U251•12KV11	250	K,M,Z	12.0	18.0	11	2.30 [58.5]	0.28 [7.0]	0.19 [4.8]	2.75 [70.0]
ST1Z5U251•12KV12	250	K,M,Z	12.0	18.0	12	2.51 [63.8]	0.28 [7.0]	0.19 [4.8]	2.75 [70.0]
ST1Z5U102•10KV04	1000	K,M,Z	10.0	15.0	4	0.78 [19.9]	0.30 [7.6]	0.17 [4.3]	2.75 [70.0]
ST1Z5U102•10KV05	1000	K,M,Z	10.0	15.0	5	0.97 [24.7]	0.30 [7.6]	0.17 [4.3]	2.75 [70.0]
ST1Z5U102•10KV06	1000	K,M,Z	10.0	15.0	6	1.16 [29.4]	0.30 [7.6]	0.17 [4.3]	2.75 [70.0]
ST1Z5U102•10KV07	1000	K,M,Z	10.0	15.0	7	1.35 [34.2]	0.30 [7.6]	0.17 [4.3]	2.75 [70.0]
ST1Z5U102•10KV08	1000	K,M,Z	10.0	15.0	8	1.54 [39.0]	0.30 [7.6]	0.17 [4.3]	2.75 [70.0]
ST1Z5U102•10KV09	1000	K,M,Z	10.0	15.0	9	1.73 [43.8]	0.30 [7.6]	0.17 [4.3]	2.75 [70.0]
ST1Z5U102•10KV10	1000	K,M,Z	10.0	15.0	10	1.91 [48.6]	0.30 [7.6]	0.17 [4.3]	2.75 [70.0]
ST1Z5U102•10KV11	1000	K,M,Z	10.0	15.0	11	2.10 [53.4]	0.30 [7.6]	0.17 [4.3]	2.75 [70.0]
ST1Z5U102•10KV12	1000	K,M,Z	10.0	15.0	12	2.29 [58.2]	0.30 [7.6]	0.17 [4.3]	2.75 [70.0]
ST1Z5U102•12KV04	1000	K,M,Z	12.0	18.0	4	0.89 [22.5]	0.31 [8.0]	0.19 [4.9]	2.75 [70.0]
ST1Z5U102•12KV05	1000	K,M,Z	12.0	18.0	5	1.10 [27.9]	0.31 [8.0]	0.19 [4.9]	2.75 [70.0]
ST1Z5U102•12KV06	1000	K,M,Z	12.0	18.0	6	1.31 [33.4]	0.31 [8.0]	0.19 [4.9]	2.75 [70.0]
ST1Z5U102•12KV07	1000	K,M,Z	12.0	18.0	7	1.53 [38.8]	0.31 [8.0]	0.19 [4.9]	2.75 [70.0]
ST1Z5U102•12KV08	1000	K,M,Z	12.0	18.0	8	1.74 [44.3]	0.31 [8.0]	0.19 [4.9]	2.75 [70.0]
ST1Z5U102•12KV09	1000	K,M,Z	12.0	18.0	9	1.96 [49.7]	0.31 [8.0]	0.19 [4.9]	2.75 [70.0]
ST1Z5U102•12KV10	1000	K,M,Z	12.0	18.0	10	2.17 [55.2]	0.31 [8.0]	0.19 [4.9]	2.75 [70.0]
ST1Z5U102•12KV11	1000	K,M,Z	12.0	18.0	11	2.39 [60.6]	0.31 [8.0]	0.19 [4.9]	2.75 [70.0]
ST1Z5U102•12KV12	1000	K,M,Z	12.0	18.0	12	2.60 [66.1]	0.31 [8.0]	0.19 [4.9]	2.75 [70.0]

¹ST1Y5P and ST1Z5U models are offered with K (± 10%), M (± 20%), and Z (+80%, -20%) capacitance tolerances. Substitute the "*" in the part number with the preferred tolerance. Inquire for additional information.

²Capacitance per disc with a 20% tolerance.

³Rated voltage per disc, dielectric withstand 150% of rated.

⁴Maximum dimension.

⁵T has a ±10% tolerance.

⁶A has a ±0.040in [1.02mm] tolerance.



Drawings and Characteristics

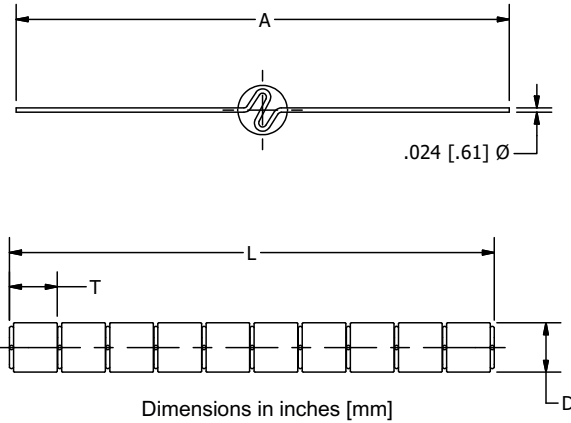

Y5P TYPICAL TEMPERATURE CHARACTERISTICS CURVE

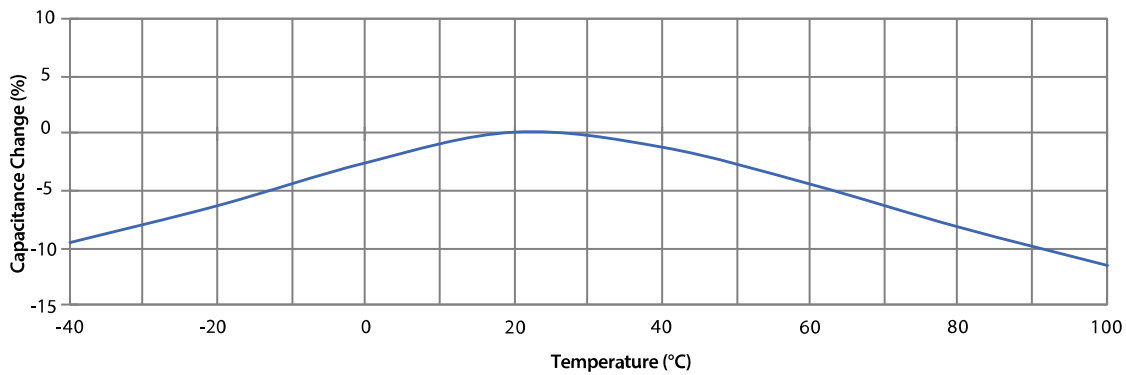

Z5U TYPICAL TEMPERATURE AND DISSIPATION CHARACTERISTICS CURVE

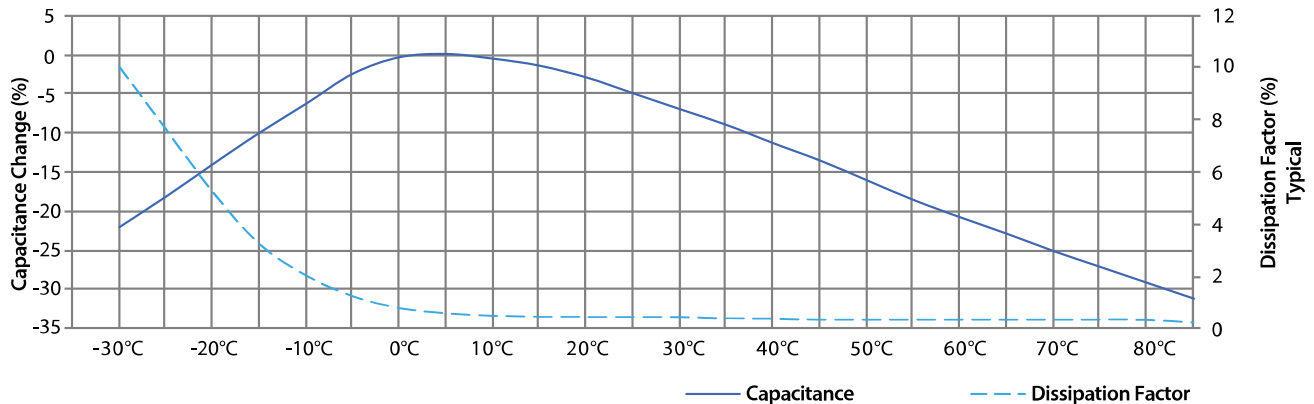



ST1 SERIES

Part Number Decoder:

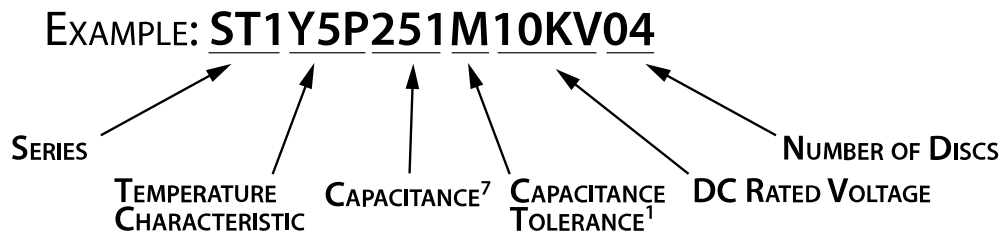

⁷Capacitance decoder:

For capacitance values less than 10pF, digits before the “R” are significant digits, while digits after the “R” are the decimal values after the significant digits. For example, 4R7 = 4.7pF, since the 4 is the significant digit while the 7 is the digit after the decimal.

For capacitance values 100pF and higher, the first and second digits are significant digits, while the third digit expresses the number of zeros to follow the two significant digits. For example, 152 = 1500pF, since the 1 and the 5 are the significant digits with 2 zeros that follow.

Note: Specifications subject to change without notice. Photo is representation only.

